

## GRAPHIC DESIGN PROGRAM

### 2019 Portfolio Requirements

#### Background

We live in a world that has become more dependent on effective communication. Graphic design plays a vital role in the process of presenting ideas, information, products and services in a national and global economy. More than ever before, industry and commerce require the expert services provided by qualified graphic designers, illustrators, and new media artists.

The aim of the Graphic Design program is to provide up-to-date training in the technology, techniques, and philosophy of graphic design. The training you will receive is geared directly to the needs of the graphic communications industry, locally and nationally.

#### What we are looking for

This is a special selection program. To meet the demands of this curriculum, applicants must possess natural aptitude for visual communication as well as display initiative, persistence and enthusiasm. We're looking for people who love to create and are passionate about design.

Applicants do not need to have prior training in design and software. We do not expect technical or artistic proficiency. The required pieces are set to assess your creativity and versatility in a variety of mediums, your ability to challenge yourself and your attention to detail and craftsmanship – all skills required of a successful designer. Pay attention to the specific requirements of each piece as to size, medium, content, mounting etc. Pieces that do not meet the stated requirement will not be assessed.

NOTE: pieces can be mounted on any type of black stock. You do not need to buy expensive matting board. Black card weight, poster board is fine.

Don't be intimidated: work hard, do your best and try to have fun with this. Show us what you can do!

#### Before you begin your portfolio

The first step in the application process is applying to the College through Enrolment Services. Once your application has been processed you will be given a student number and access to your online account. The deadline for application to Red River College is February 28, 2019.

#### When your portfolio is completed

Portfolios must be submitted on or before 4:30 pm, WEDNESDAY, APRIL 24, 2019, during office hours. We encourage applicants to submit work prior to the deadline as no portfolios will be accepted after this deadline regardless of the circumstances. Avoid waiting until the last day and risk missing the deadline.

#### Mail or deliver your completed portfolio to:

Graphic Design Admission Committee  
Exchange District Campus  
c/o Student Service Centre  
P104 – 160 Princess Street  
Winnipeg, MB R3B 1K9

#### HOURS

Monday – Thursday: 8:00 am – 4:30 pm

Friday: 9:00 am – 4:00 pm

The student service centre is located on the main floor of Exchange District Campus, Princess Street Building.

#### What happens next?

In late May, after the admission committee has assessed all of the portfolios, you will be contacted by RRC Enrolment Services letting you know if your portfolio score falls within acceptable range. If so, you will be required to attend an informational session in late May in which we will hand out all of the specs for the laptop and art kit, and also give you a chance to ask questions about the program. We will then begin sending out letters of admittance to qualified applicants based on portfolio scores in descending order until all available seats are filled. Five to seven people with the lowest acceptable portfolio scores will be placed on a waitlist. Once the program starts in September, anyone still on the waitlist will have their application cancelled and must re-apply if they wish to try again for program entry in the following year.

If you are not accepted into the program, you will need to pick up your portfolio from the Creative Arts Office, Room W302, 160 Princess Street prior to noon Friday, September 6, 2019, otherwise it will be disposed of.

If you have any questions please contact the Program Coordinator Diane Livingston by e-mail at [dlivingston@rrc.ca](mailto:dlivingston@rrc.ca)

To see more of what our program offers visit our website at [www.rrc.ca/creativearts/graphic-design](http://www.rrc.ca/creativearts/graphic-design)

# The Portfolio Package

## Preparing your portfolio

All work must be submitted flat and unfolded in a package not to exceed 26" x 38." All packages containing portfolios must be easily accessible and secure. The college is not responsible for damage caused by poorly packaged portfolios.

It is advisable to consider purchasing an inexpensive portfolio case to contain your work. A cardboard case is sufficient and is generally available at any art supply store. If you are unable to purchase a case, one can be constructed using two pieces of rigid cardboard cut to a maximum size of 26" x 38" and secured around the bottom and on two sides with a strong tape (Fig. 1).

Neatly print your full name, RRC student number, and address on the outside top left of your portfolio case, and also on the back of each individual item in the portfolio (see figure 2 & 3). Clearly mark each submitted piece to correspond with the list of requirements (example: #1 Self Portrait).

We require all pieces be mounted on a supporting black card with 2" margins to protect applicant's work and to improve presentation.

All pieces submitted must conform to sizes stated.

All applicants are urged to use discretion in selecting subject matter for this portfolio. The admission committee will not accept any portfolio which, in its opinion, depicts scenes of overt violence, sexism, or racism.

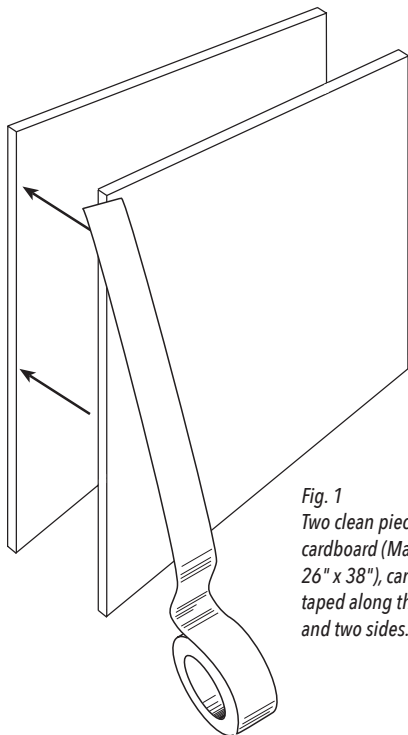

Fig. 1  
Two clean pieces of flat cardboard (Maximum 26" x 38"), carefully taped along the bottom and two sides.

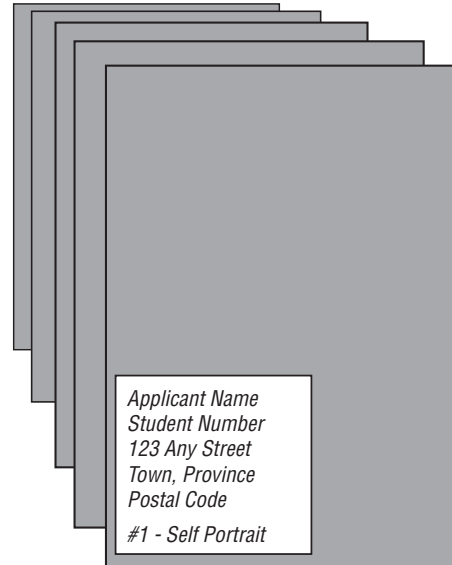

Fig. 2  
All portfolio items must be mounted on black card and have your name, student number and address printed clearly on the back of each piece. Also each piece must be marked to indicate which requirement it fulfills (example: #1 Self Portrait).

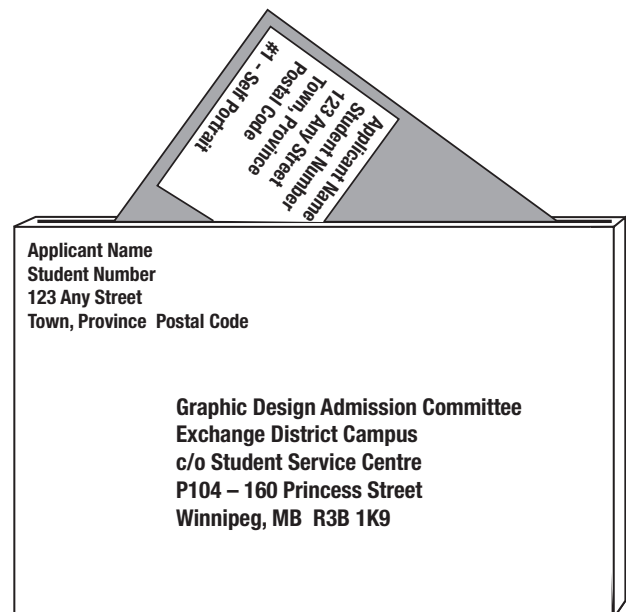

Fig. 3  
Required labels.

**NOTE: Portfolios without address labels will not be accepted.**

## PORTFOLIO PART A

# Written Components

For both written components (Items 1 and 2) type up and format your content neatly, write clearly and pay attention to grammar and spelling. Staple both sheets together and place loose into the portfolio. Do not mount on black card or place in a folder.

### ITEM 1

#### Résumé

Prepare a type written résumé stating your educational background (high school art courses or other art training) and any work experience. Please list your hobbies and interests as well.

### ITEM 2

#### Statement of Intent

Tell us a little about yourself by answering the three questions below. Before you begin, do some research on our industry and the types of work our graduates do. Keep your answers short (75 to 100 words per question).

- a) Why do you want to study graphic design?
- b) What sort of creative projects do you do in your free time?
- c) Which portfolio piece did you find the most challenging and why?

The written portion of the portfolio will be evaluated on the following: presentation/formatting, industry awareness, grammar and spelling.

## PORTFOLIO PART B

# Creative Components

### PREAMBLE - The importance of drawing.

Our ability to communicate successfully in visual terms requires the broadening of our powers of perception and response to the world we encounter around us.

In the creation of visual images, insight is the important issue. Of particular importance to the artist is the ability to process complex visual information. Drawing from direct observation is the most effective way to develop and demonstrate this ability.

### IMPORTANT NOTES:

- All drawings in the following sections should be done from direct observation. Avoid using photographs as reference.
- Complete your work to the sizes indicated and then mount on black card stock adding 2" margins on all sides. You can use a wide variety of material to mount your work on. Economical poster board will work fine. You can also use a more expensive material such as matte board.
- All measurements are given as width x height and as the size before mounting.
- Take your time when creating the pieces and fully develop the work. Craftsmanship is important.

### ITEM 1

#### Self Portrait

Create a natural or stylized portrait. With the aid of a large mirror, execute the portrait from direct observation, not from photo reference.

Compose the drawing to include your upper body and hands. In your non-drawing hand, hold an object that has special meaning to you. Be inventive. Your work will be evaluated on the following: use of value/colour, artistry, composition, rendering/craftsmanship.

MEDIUM: ANY TRADITIONAL COLOUR MEDIUM.

MINIMUM SIZE: 16" X 20" MAXIMUM SIZE: 18" X 22"

MOUNTED ON BLACK CARD WITH 2" BORDERS

## ITEM 2

### Paper Collage

Choose an animal you would like to illustrate. Start by collecting different types of papers such as; magazines, newspapers, cards, drawing papers or wallpaper. Consider their colours, weight and textures. Sketch out the shape of your animal on a sheet of heavy paper. Start cutting out paper using a variety of sizes, colour, tone and texture to create form. Be creative. The final work can look abstract or realistic. Finally, cut out some letters to spell out the name of the animal and add to the piece. Mount your piece on black card.

Your work will be evaluated on the following: creativity, use of colour, tone and texture, craftsmanship.

MEDIUM: PAPER COLLAGE.

REQUIRED SIZE: 16" x 20" OR 20" X 16"

MOUNTED ON BLACK CARD WITH 2" BORDERS

## ITEM 3

### Interior Perspective Drawing

Complete a 2 or 3 point perspective drawing of an interior public space such as a local library or public building. The provincial legislature or university buildings are always good choices. The location should have a high ceiling (at least 2 stories high). Draw from a dynamic angle, either from the ground looking upward or from a high vantage point looking downward. Focus on an area where various planes meet (ceiling, walls and floor). Work on site and not from photos.

Complete the drawing by adding tone (light to dark shading) to the whole drawing to create a strong sense of depth. In small letters at the bottom right hand corner of your drawing, write the location of your drawing.

Important: If you are unsure, do some research into 2 and 3 point perspective drawing to understand the concepts. Check out your local library or go online to view tutorials on the subject. Demonstrating a strong understanding of perspective is the most important aspect of the drawing when evaluated. Avoid 1 point perspective drawings.

Your work will be evaluated on the following: use of value and tone, relevance/perspective, composition, craftsmanship/rendering.

MEDIUM: BLACK PENCILS

MINIMUM DIMENSIONS: 24" x 18" OR 18" X 24"

MOUNTED ON BLACK CARD WITH 2" BORDERS

## ITEM 4

### Typographic Composition

Choose one of the words from the list below and create a typographic composition by using found objects which you feel connect with the meaning of the word. Use these objects and their shapes to spell out the word. Create only the letters found within the selected word. Your composition should be arranged on a solid white or black background and photographed. Attention to detail with respect to layout (positioning of letters), scale, colour, lighting and craftsmanship are important. Ensure your composition is crisp and clean. You can have your photo printed at Staples, the UPS Store, or any other location that will print colour laser or photos. Your work will be evaluated on the following: concept/theme, design, creativity, craftsmanship.

Water

Air

Fire

MEDIUM: FOUND OBJECTS ARRANGED, DIGITALLY PHOTOGRAPHED AND PRINTED.

PRINT OUT SIZE: 11" X 17" OR 17" X 11"

MOUNTED ON BLACK CARD WITH 2" BORDERS

## ITEM 5

### Illustrated Map

Create an illustrated tourism map of a Winnipeg neighbourhood. Choose from Wolseley, the Exchange District or St. Boniface. If you are a rural candidate, choose your local downtown.

The map should depict a minimum of a 4 block area with four or five points of interest. Label the points of interest and the street names and include anything else you feel would be of interest to a visitor to this neighbourhood. Somewhere in the map include the name of the neighbourhood.

The illustration style, typefaces and colours should convey the tone and character of the neighbourhood.

Your work will be evaluated on the following: typography/lettering, imagery, layout/composition, craftsmanship/attention to detail.

MEDIUM: HAND RENDERED IN ANY TRADITIONAL COLOUR MEDIUM

REQUIRED SIZE: 11" X 17" OR 17" X 11"

MOUNTED ON BLACK CARD WITH 2" BORDERS

## ITEM 6

### Personal Work

Select four or five items of your best personal work. You may include sketches, finished drawings, paintings, and posters that are within the size restrictions of the portfolio. Show us a range of pieces in a variety of mediums.

Avoid the following types of work:

- projects from tutorials
- highly derivative work that copies an existing style or work
- crafts
- pieces that all use the same technique or of the same subject matter

Sculpture, framed artwork, or other over-size pieces must be submitted in the form of printed photographs only. Digital work should be supplied as a print-out. All work must be carefully mounted on black card. No slides or computer discs will be accepted.

Your work will be evaluated on the following:  
rendering, composition, creativity, range of work.

**Mail or deliver your completed portfolio by the deadline of Wednesday, April 24, 2019 to:**

Graphic Design Admission Committee  
Exchange District Campus  
c/o Student Service Centre  
P104 - 160 Princess Street  
Winnipeg, MB R3B 1K9

**HOURS**

Monday – Thursday: 8:00 am – 4:30 pm

Friday: 9:00 am – 4:00 pm

The student service centre is located on the main floor of Exchange District Campus, Princess Street Building.