

Name:

Equilibrium Provincial Exam Review Questions

1. A 12 kg cart on a 23° frictionless incline is connected to a wall as shown.

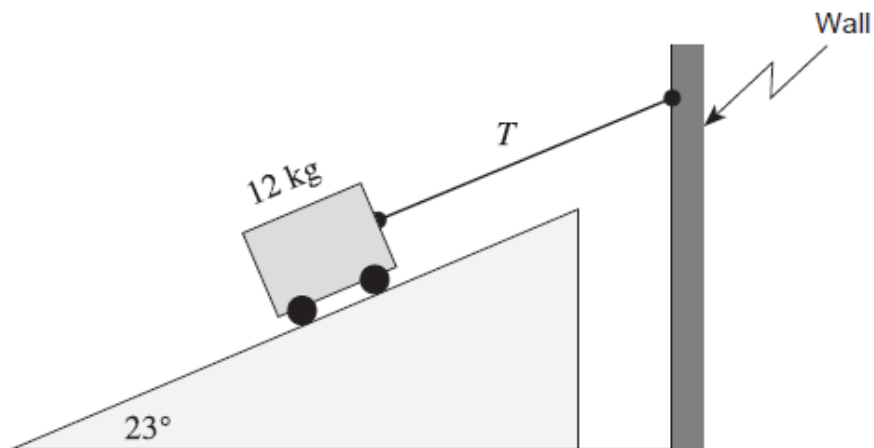

What is the tension T in the cord?

2. An 85 kg object is suspended from a ceiling and attached to a wall.

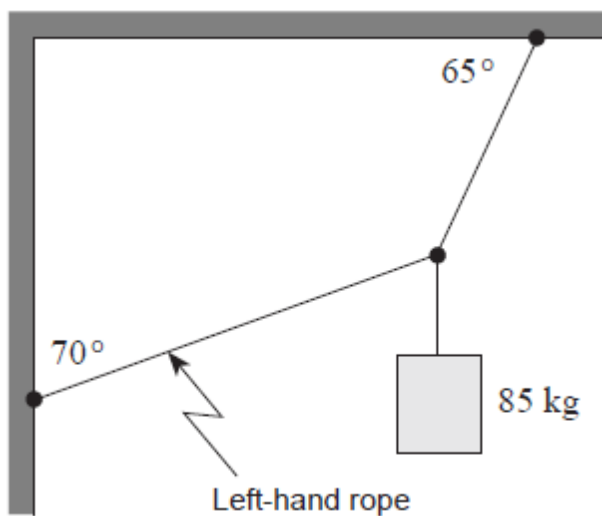

What is the tension in the left-hand rope?

3. A student stands on a uniform 25kg beam. The scale on the right end reads 350N.

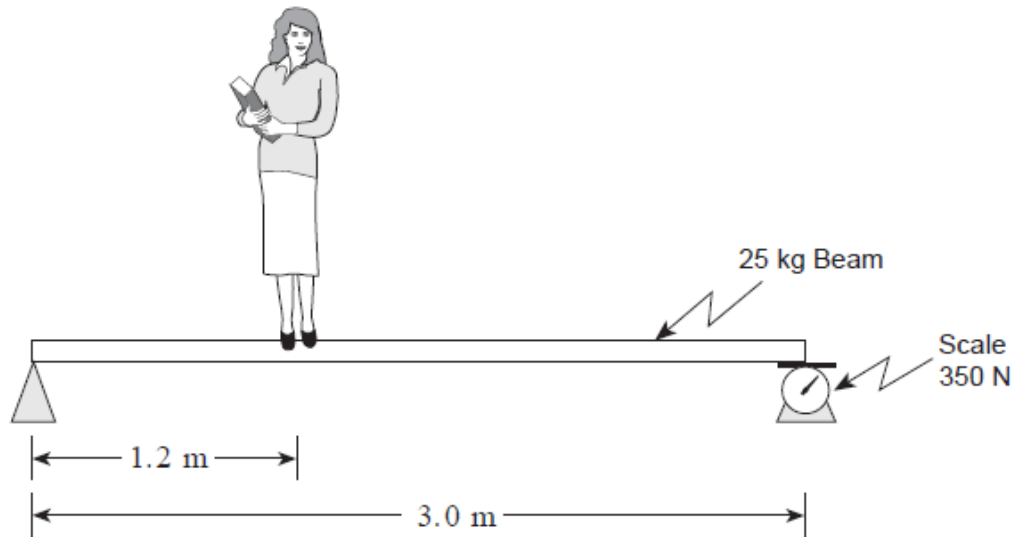

What is the mass of the student?

4. A 6.0m uniform beam of mass 32kg is suspended horizontally by a hinged end and a cable. A 93kg object is connected to one end of the beam.

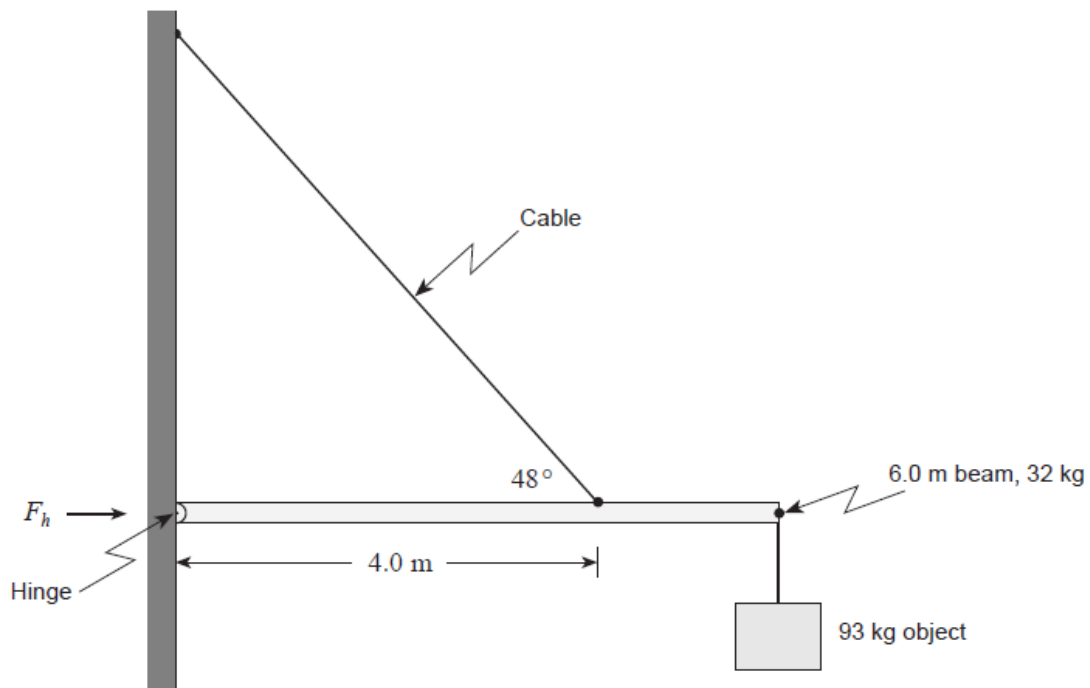

What is the magnitude of the horizontal force F_h that the hinge exerts on the beam?

5. A body is in rotational equilibrium when

- A. $\sum \tau = 0$
- B. $\sum F = 0$
- C. $\sum p = 0$
- D. $\sum E_k = 0$

6. A 110kg object is supported by two ropes attached to the ceiling.

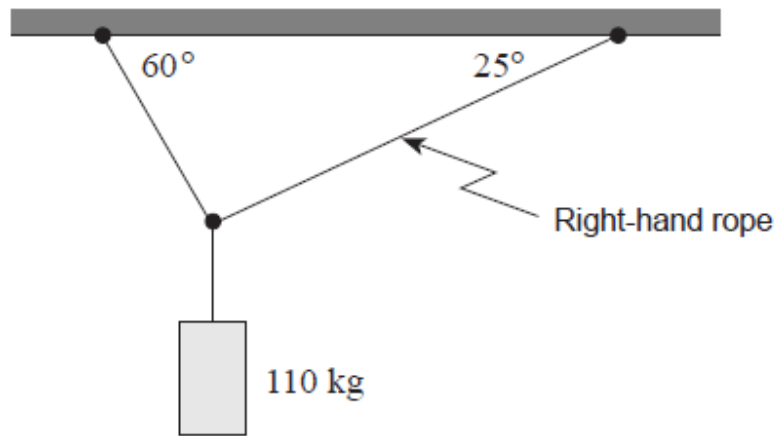

What is the tension in the right-hand rope?

7. A 35kg uniform plank is balanced at one end by a 55kg student as shown.

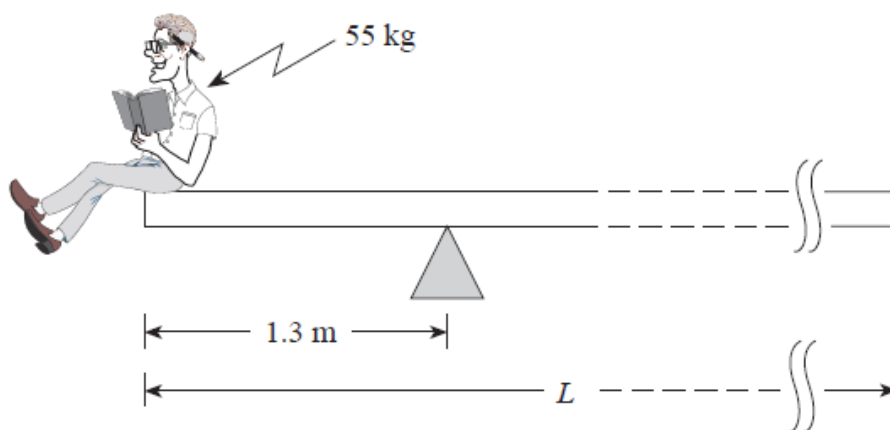

What is the overall length of this plank?

8. A 6.0m uniform beam of mass 25kg is suspended by a cable shown. A 85 kg object hangs from one end.

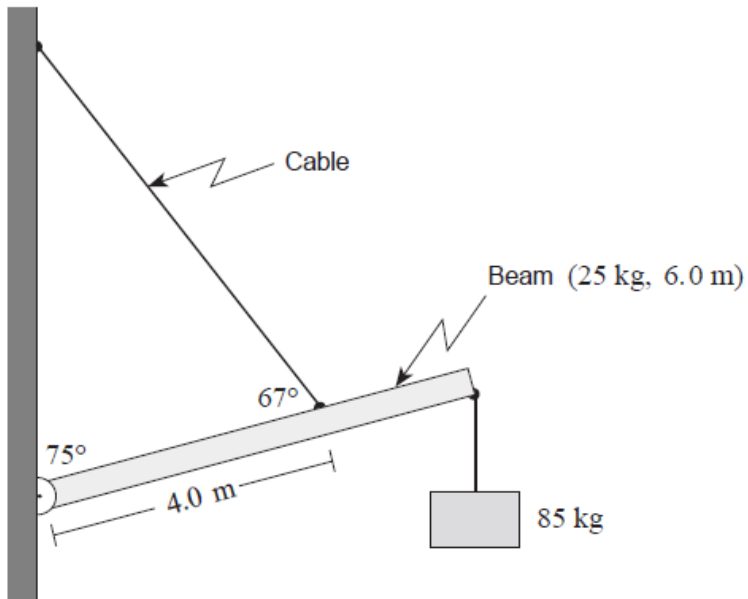

What is the tension in the cable?

9. A 150kg object is suspended from a ceiling and attached to a wall.

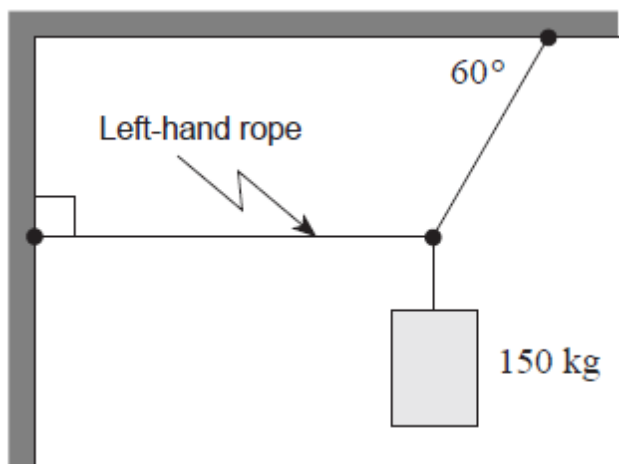

What is the tension in the left-hand rope?

10. A 4.2m long uniform post is supported by a cable having a tension of 1 700 N. What is the mass of this post?

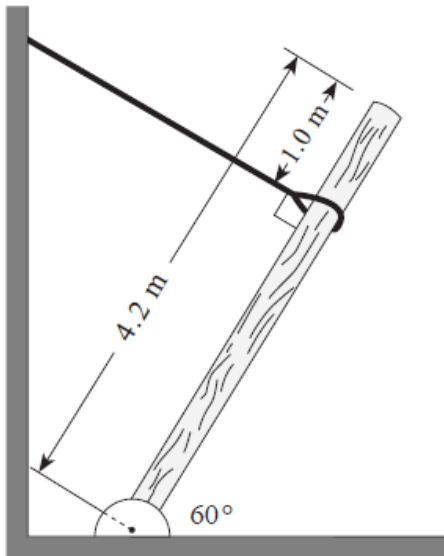

11. A circus performer on a unicycle of total mass 55kg rides across uniform 30kg beam. The supports are placed equal distances from the ends of the beam.

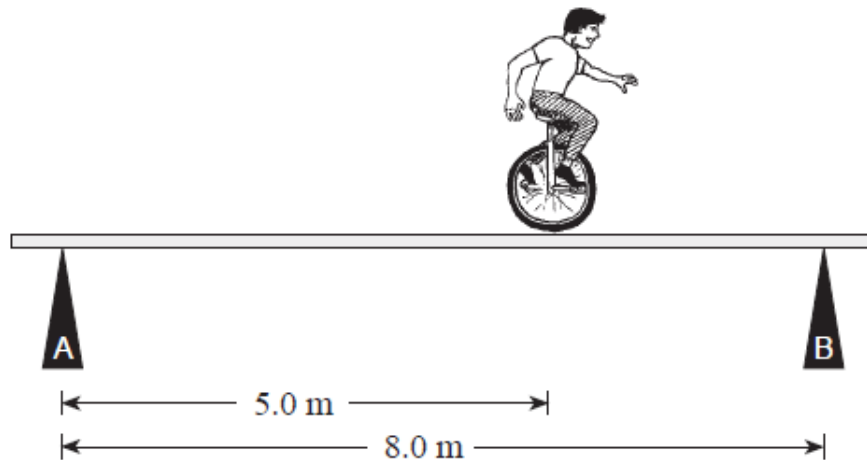

a) When he is in the position shown, determine the forces exerted by the supports on the beam

b) As the performer moves towards the right, the force exerted by support B will

- Remain the same
- Increase
- Decrease

c) Using principles of physics, explain your answer to b).

12. A force F is applied to a uniform horizontal beam as shown in the diagram below.

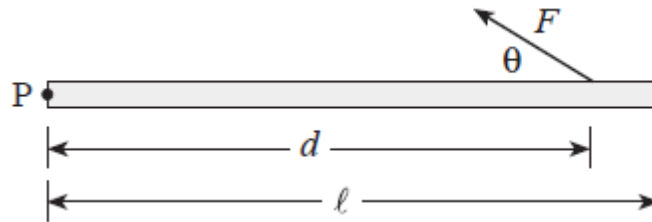

Which of the following is a correct expression for the torque on the beam about pivot point P due to this force?

- A. $F \sin \theta \cdot d$
- B. $F \sin \theta \cdot d / \ell$
- C. $F \cos \theta \cdot d$
- D. $F \cos \theta \cdot d / \ell$

13. A 35kg traffic light is suspended from two cables as shown in the diagram.

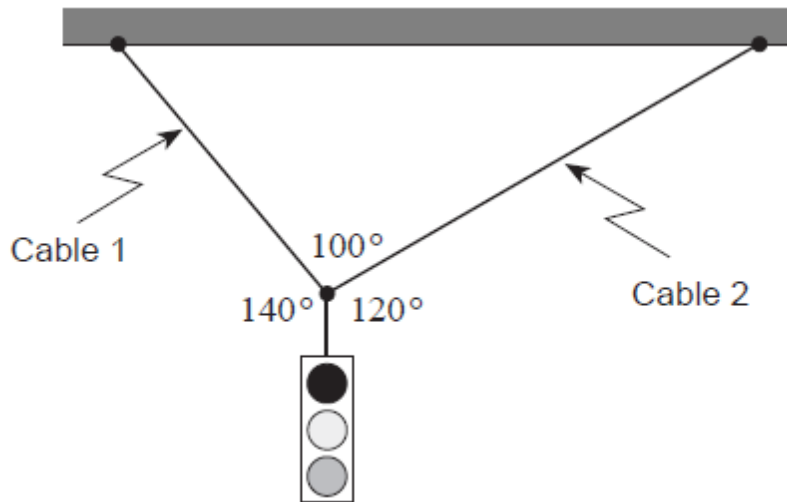

What is the tension in each of these cables?

14. A uniform 1.5kg beam hinged at one end supports a 0.5kg block. The beam is held level by a vertical 0.80kg rod resting on a Newton scale at the other end.

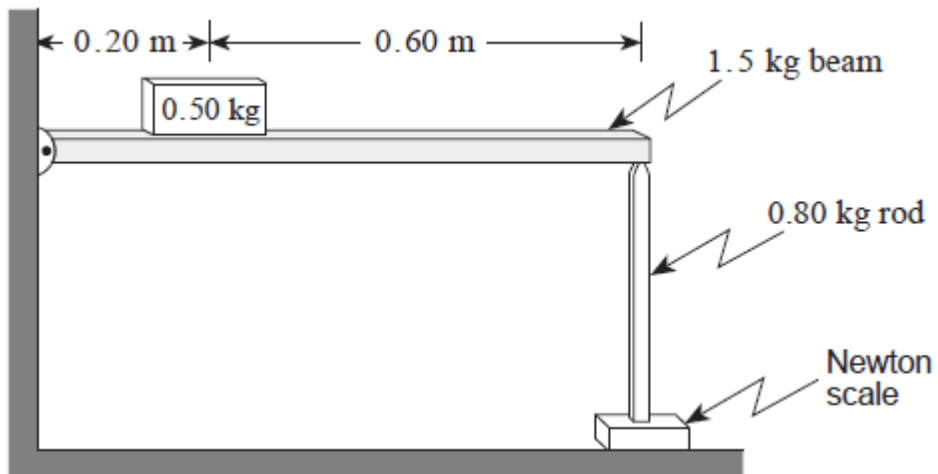

What is the reading on the scale?

- A. 8.6N
- B. 9.1N
- C. 16N
- D. 27N

15. A 450N chandelier is supported by three cables as shown in the diagram.

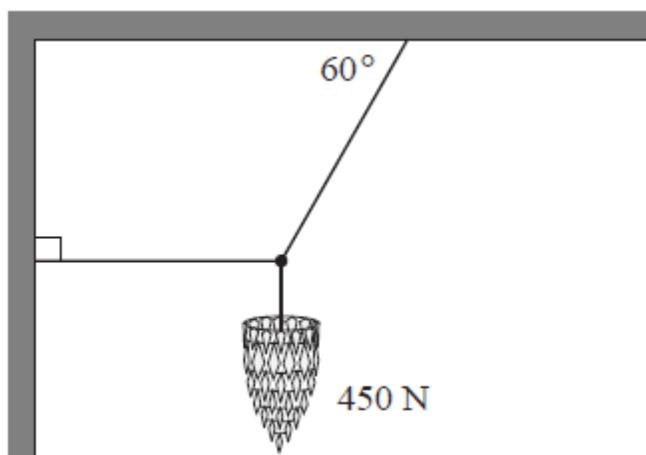

What is the tension in the horizontal cable?

16. A beam is to be kept horizontal by a cord. In which of four situations below would the tension in the cord be the least?

A.

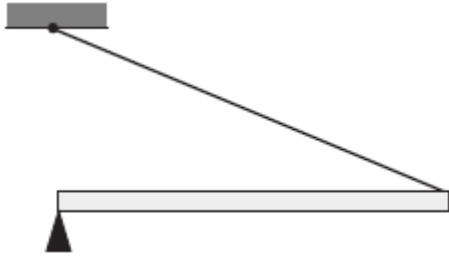

B.

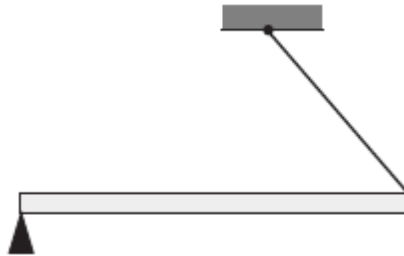

C.

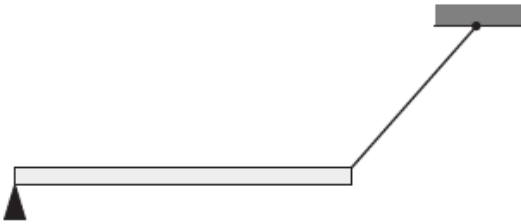

D.



17. A crane is used to lift one end of a uniform 15m long pipe with a mass of 730kg as shown in the diagram below.

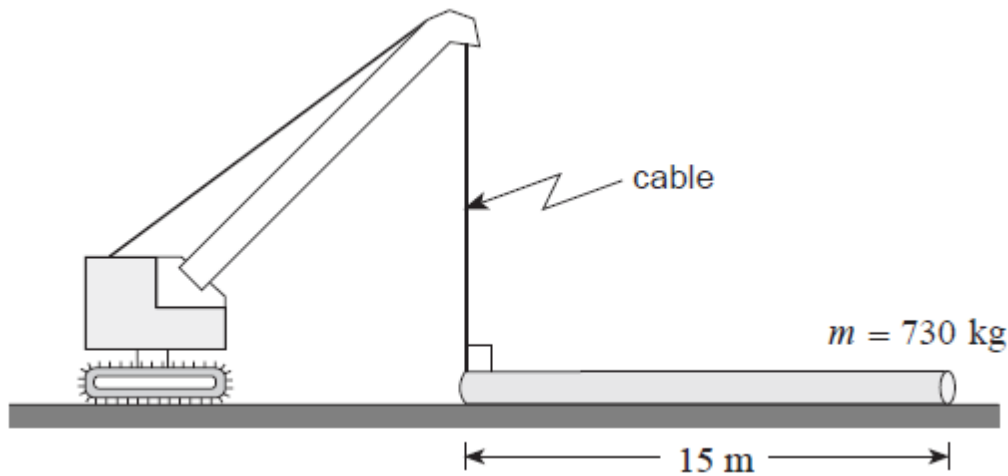

What is the minimum force of tension in the crane cable to just lift the end of the pipe off of the ground?

18. A traffic sign hangs from two cables as shown.

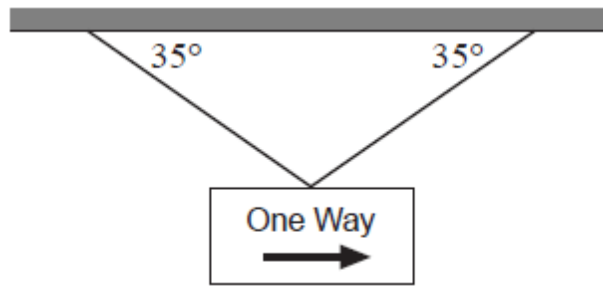

If the tension in each cable is 220N, what is the weight of the sign?

19. Which of the four problems shown requires the application of torque?

A.

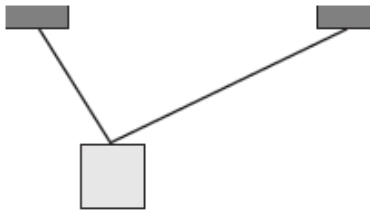

What is the tension in the supporting cables?

B.

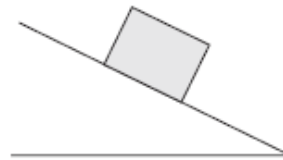

What is the friction force acting on the block?

C.



What is the acceleration of the puck?

D.

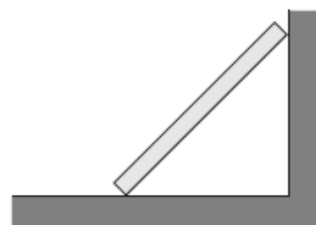

What force does the wall exert on the board?

20. A uniform 6.0m-long boom has a mass of 55kg. It is kept in position by a restraining cable attached three-quarters of the way along the boom.

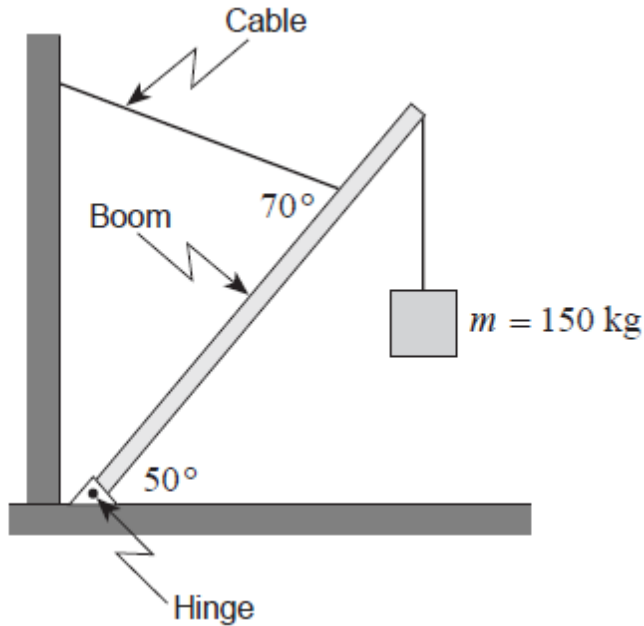

What is the tension in this cable when the boom supports a 150kg mass as shown?

21. A metre stick, as seen from above, is sitting on a table and is then subjected to two forces of equal magnitude as shown. In which case would the metre stick be in rotational equilibrium?

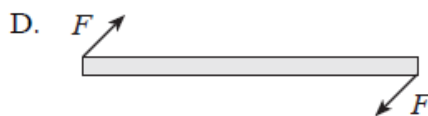
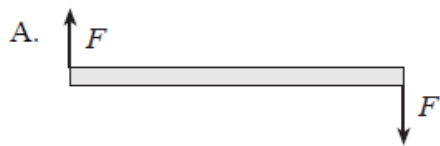

22. A uniform 0.122kg rod of 0.90m length is used to suspend two masses as shown below.

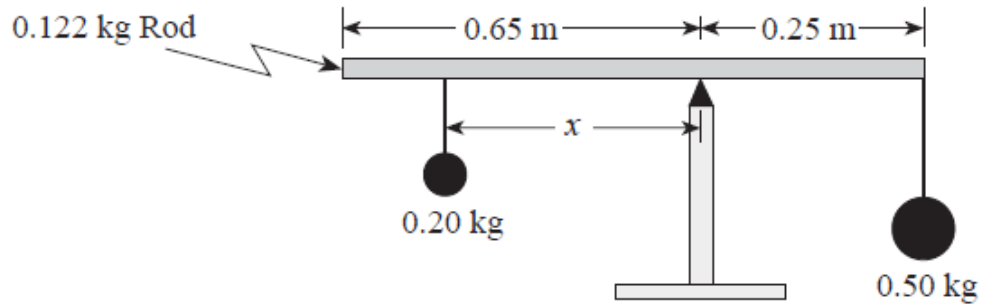

At what distance x should the 0.20kg mass be placed to achieve static equilibrium?

23. A uniform 1200kg steel girder is supported horizontally at its endpoints as shown in the diagram.

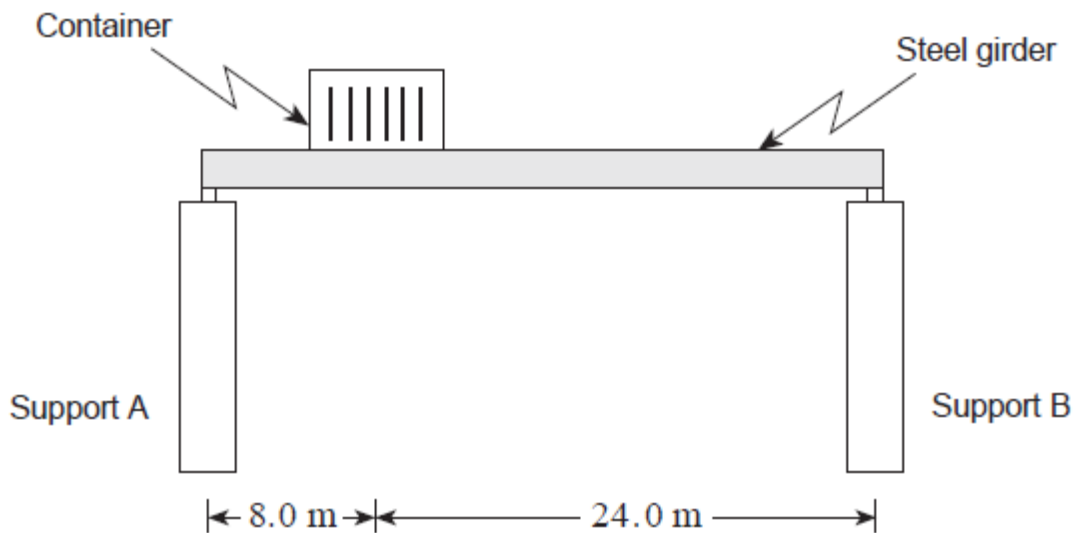

What are the upward forces at the girder end points when it is bearing a 3700kg shipping container 8.0m from support A?

Equilibrium Provincial Exam Review Answers

1. 46N (Aug. 1999 #5)
2. $5.0 \times 10^2 \text{N}$ (Aug. 1999 #10)
3. 58kg (Aug. 1999 #11)
4. $1.4 \times 10^3 \text{N}$ (Aug. 1999 #3LA)
5. A (Jan. 1999 #9)
6. $5.4 \times 10^2 \text{N}$ (Jan. 1999 #10)
7. 6.7m (Jan. 1999 #11)
8. $1.5 \times 10^3 \text{N}$ (Jan. 1999 #3LA)
9. $8.5 \times 10^2 \text{N}$ (June 1999 #11)
10. $5.3 \times 10^2 \text{kg}$ (June 1999 #12)
11. a) $F_B = 4.8 \times 10^2 \text{N}$, $F_A = 3.5 \times 10^2 \text{N}$ b) increase
c) As the cyclist moves toward B the lever arm increases, creating a larger clockwise torque.
To maintain static equilibrium the counter clockwise torque must also increase and since d is fixed ($d = 8.0\text{m}$), the force must increase. (June 1999 #3LA)
12. A (Jan. 2000 #10)
13. $T_1 = 3.0 \times 10^2 \text{N}$, $T_2 = 2.2 \times 10^2 \text{N}$ (Jan. 2000 #3LA)
14. C (Jan. 2000 #12)
15. $2.6 \times 10^2 \text{N}$ (June 2000 #11)
16. D (June 2000 #12)
17. $3.6 \times 10^3 \text{N}$ (June 2000 #13)
18. $2.5 \times 10^2 \text{N}$ (Aug. 2000 #11)
19. D (Aug. 2000 #10)
20. $1.6 \times 10^3 \text{N}$ (June 2000 #3LA)
21. B (Jan. 2001 #12)
22. 0.50m (Jan. 2001 #13)
23. $F_A = 3.3 \times 10^4 \text{N}$, $F_B = 1.5 \times 10^4 \text{N}$ (Aug. 2000 #3LA)