

Lesson Six: Surface Area and Volume of Irregular Shapes

In lesson 3 you found the area of irregular shapes by using the formulas for shapes that you know, and adjusting them for the given irregular shape. You may have added areas (composite shapes), subtracted areas (shaded area), or found a fraction of a regular area.

All of these skills can be applied to 3D shapes as well.

Example 1: Composite 3D Shape

The following shape is a grain silo. It stores grain in a dry place until needed (or sold) by a farmer. It is made up of a cylinder with a cone (with 8 m height) on top. Calculate the volume of this composite shape.

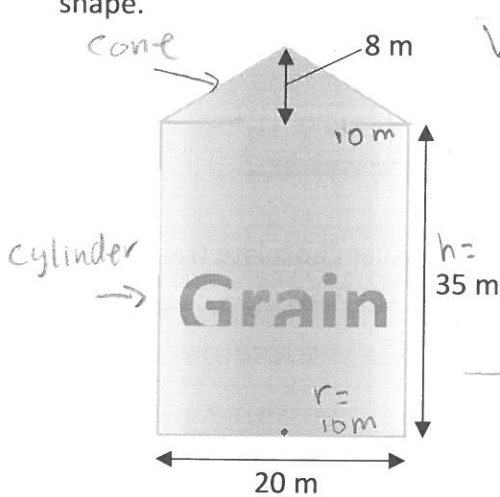

$$\text{Volume (silo)} = \text{Volume Cone} + \text{Volume cylinder}$$

$$\begin{aligned} \text{Volume of cone} &= \frac{1}{3} \pi r^2 h \\ &= \frac{1}{3} \times \pi \times 10^2 \times 8 \end{aligned}$$

$$\text{Volume cone} = 3665.19 \text{ m}^3$$

$$\begin{aligned} \text{Volume of cylinder} &= \pi r^2 h \\ &= \pi \times 10^2 \times 35 \end{aligned}$$

$$\text{Volume (cylinder)} = 10995.57 \text{ m}^3$$

$$\begin{aligned} \text{Volume of silo} &= 3665.19 \text{ m}^3 + 10995.57 \text{ m}^3 \\ &= 14660.76 \text{ m}^3 \end{aligned}$$

Example 2: 'Shaded' Volume

A company manufactures cement sewer pipes. The pipes have a thickness of 4 inches, and the hollow portion has a diameter of 36 inches. The pipes are sold in 20 foot lengths. Calculate the volume of cement required to manufacture one pipe.

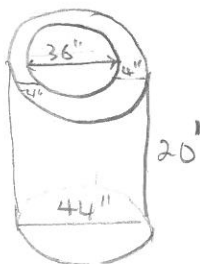
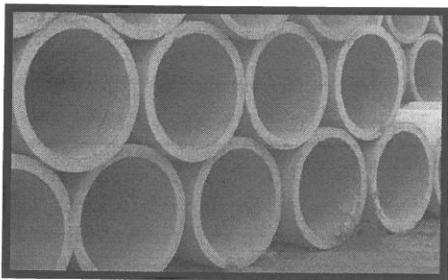

$$\begin{aligned} 36'' &= 3' \\ 44'' &= 3' 8'' \\ &= 3.66' \end{aligned}$$

$$\text{Volume of cement} = \text{Outer pipe} - \text{Inner pipe}$$

$$\begin{aligned} \text{Volume of outer pipe} &= \pi r^2 h \\ &= \pi \times (3.66')^2 \times 20' \\ &= 841.7 \text{ ft}^3 \end{aligned}$$

$$\begin{aligned} \text{Volume of inner pipe} &= \pi r^2 h \\ &= \pi \times (3')^2 \times 20' \\ &= 565.5 \text{ ft}^3 \end{aligned}$$

$$\begin{aligned} \text{Volume of Cement} &= 841.7 \text{ ft}^3 - 565.5 \text{ ft}^3 \\ &= \underline{\underline{276.2 \text{ ft}^3}} \end{aligned}$$